

PARTICOLARE LINEA INTERRATA AREE CARRABILI

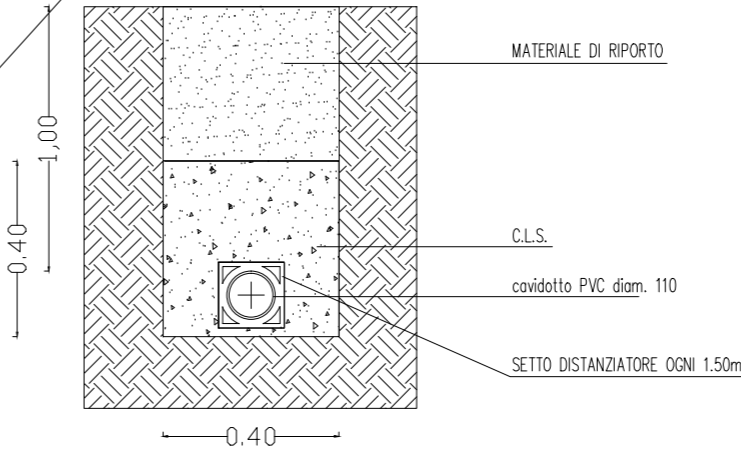

PARTICOLARE LINEA INTERRATA AREE NON CARRABILI

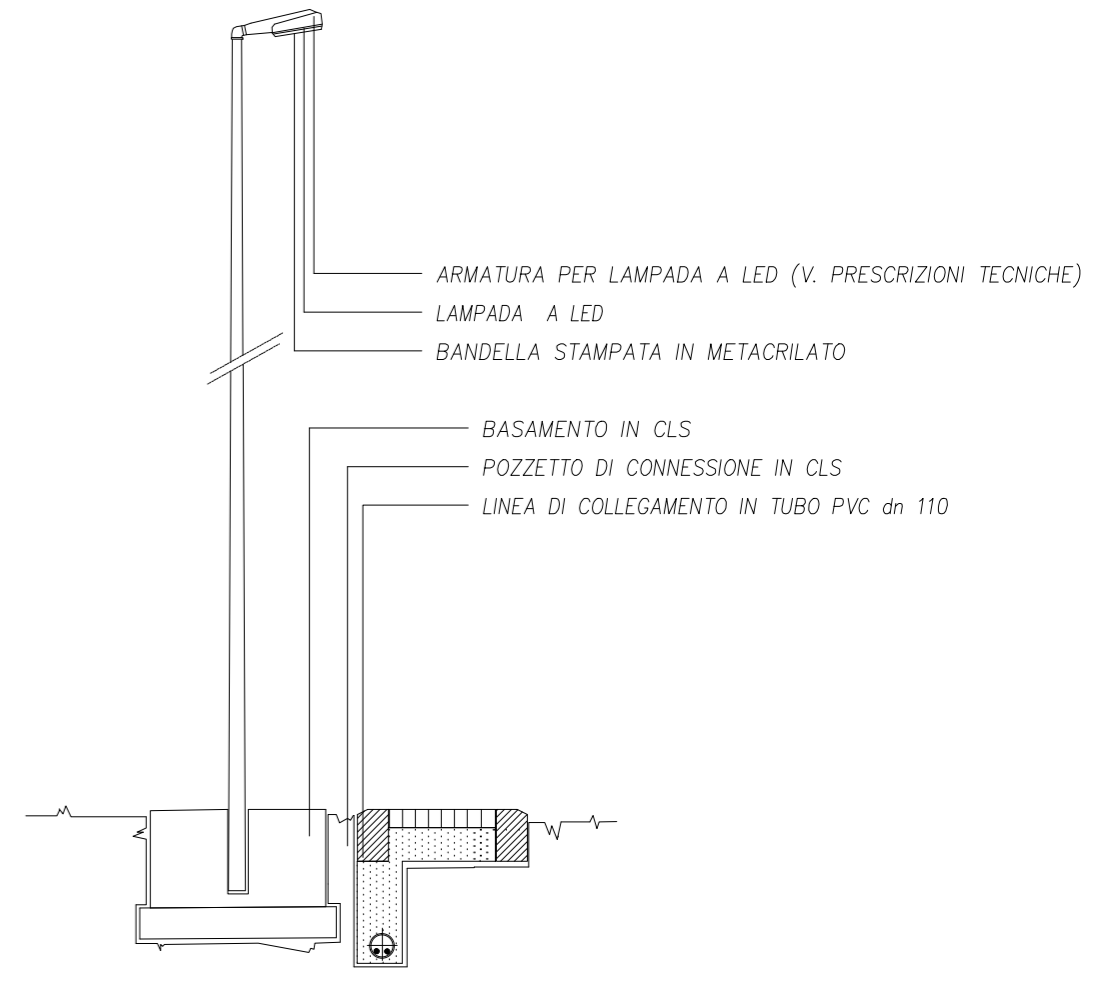
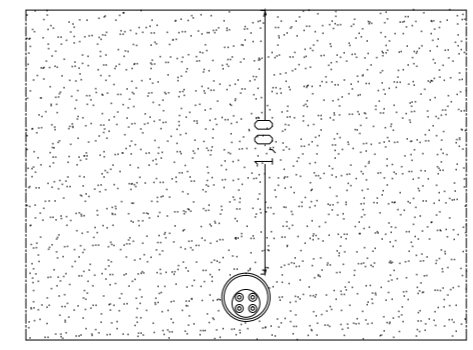

COMUNE DI ORIA
PROVINCIA DI BRINDISI

PROGETTO DEFINITIVO-ESECUTIVO

**INFRASTRUTTURE DI SUPPORTO
ALLA ZONA PIP**

PROGETTISTA
Ing. Lorenzo LACORTE - Responsabile U.T.C.



TAVOLA 6 - IMPIANTO ILLUMINAZIONE

STRADA PROVINCIALE ORIA - SAN COSIMO